

WAKITEC

AUTOMATIC PACKING MACHINE-HORIZONTAL

TYPE / APM-H



※Stock table is optional.

Features

Performs automatic packing in as low as 5 seconds

- Allows user setting of various types of formed products with the shortest setup change time. Advanced model that automatically performs packing of 50 packaging container products in as low as 5 seconds.

Easy setting via LCD screen

- By setting product dimensions (height, width, length) on the LCD screen via 6 setting points, which include the vertical and horizontal positions of the packing film former, the position of the product pusher, and the height of the seal bar, automatic movement and settings are completed in a few seconds, enabling quick start of packing operation.

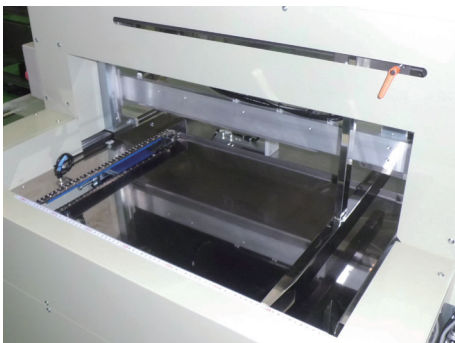

Product loading unit

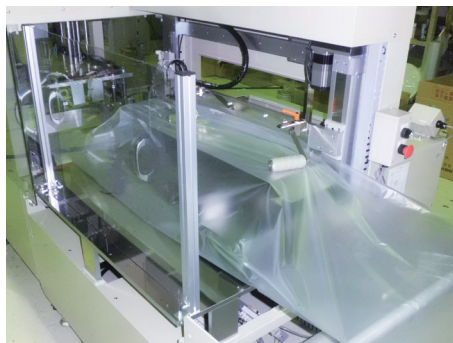

Packing bag & former unit



Seal and finished product output unit

WAKISAKA ENGINEERING CO.,LTD. **WAKITEC**

APM-H TYPE External Drawing

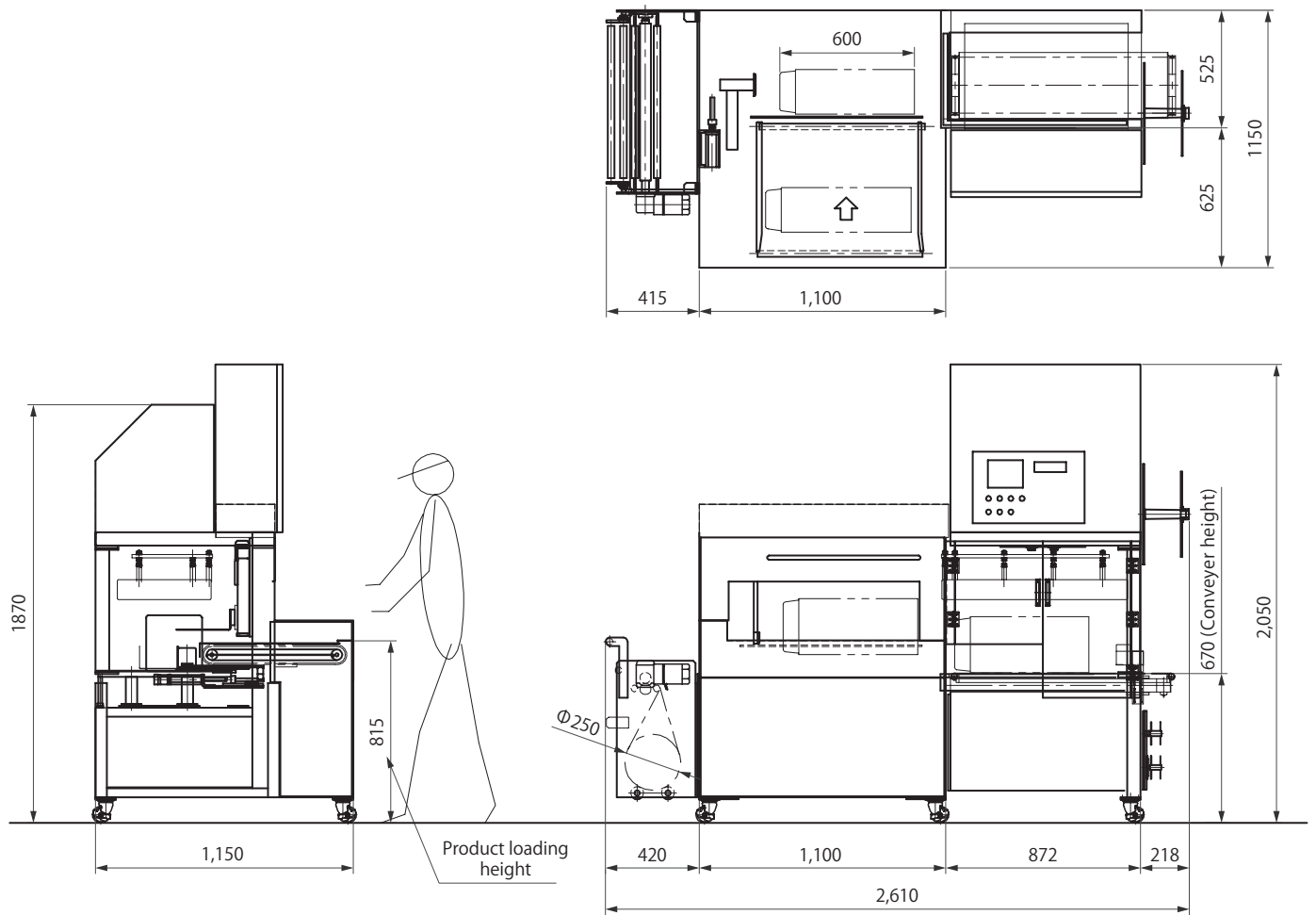

MAIN SPECIFICATIONS

Product size	Maximum 250mm(H) × 280mm(W) Minimum 80mm(H) × 100mm(W)
Product stacking length	100~650mm(L)
Packing film (Raw film)	Double-folded rolled sheets, maximum 650mm (W) × $\phi 250$ mm (roll circumference)
Processing capacity (Maximum)	5 seconds per 1 unit
Machine weight	1.3t
Power supply	AC 3-phase, 200V, 50/60Hz, TOTAL CAPACITY: 6.5kW (30A)
Operating air	100ℓ/min (5kg/cm ² or more)

